

## CB 160 POMPĂ CENTRIFUGALĂ CU 2 TURBINE

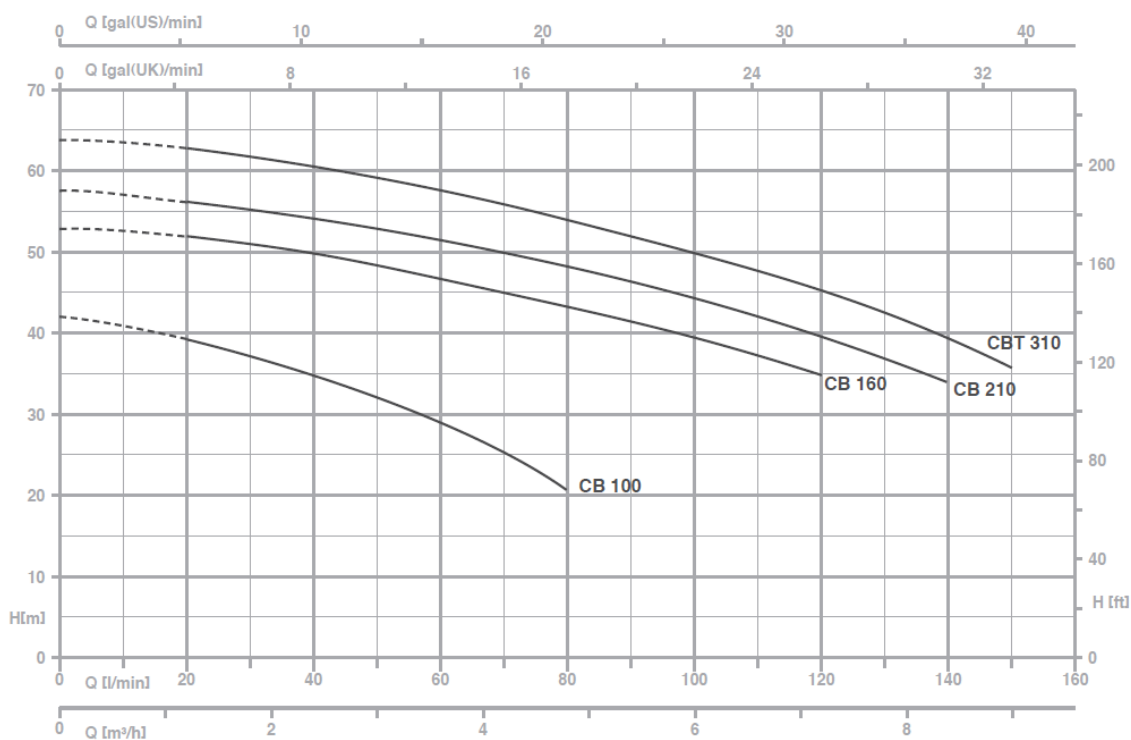



Putere absorbită P1:	2,3 kW
Putere P2:	1,1 kW
Alimentare:	230 V / 50 Hz
Înălțime de refulare max.:	53 m
Debit max.:	7200 l/h
Diametru de aspirație:	1 ¼"
Diametru de refulare:	1"

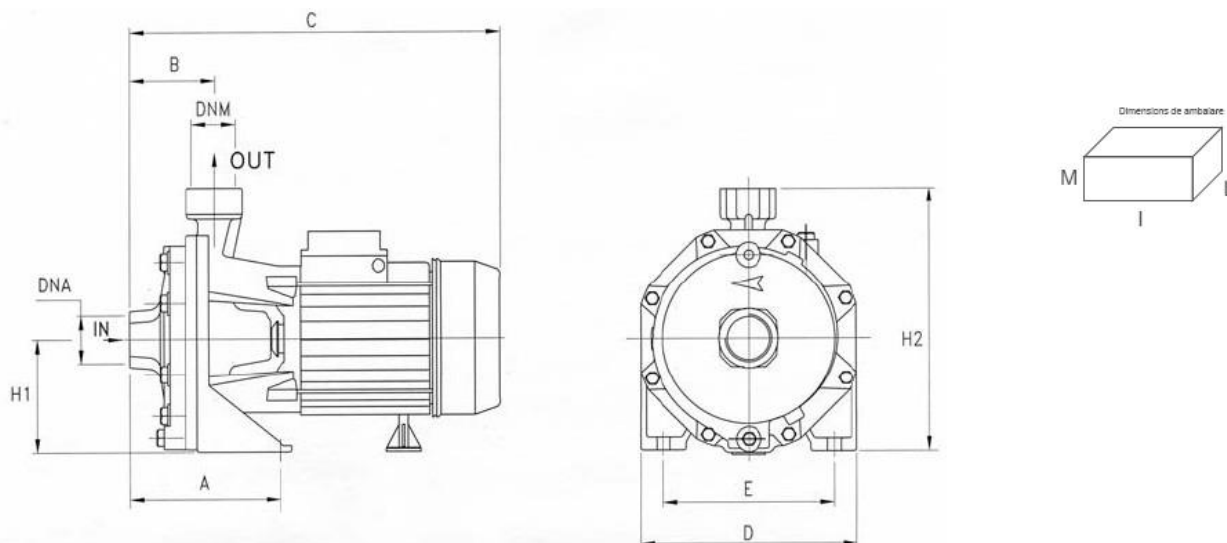

Debit Q (m <sup>3</sup> /h – l/min)										
0	0.6	1.2	1.8	2.4	3.6	4.8	6	7.2	8.4	9
0	10	20	30	40	60	80	100	120	140	150
Înălțime de refulare H (m)										
53	52.5	52	51	50	46.9	43.3	39.7	35	-	-

Temperatura maximă a apei:	50 °C
Carcasă pompă:	fontă
Suport motor:	fontă
Rotor pompă:	Noryl®
Etanșare mecanică:	ceramică – grafit
Arbore motor:	otel AISI 303
Clasă de izolație:	F
Clasă de protecție:	IP44
Protecție termică:	Da



MODEL	DIMENSIUNI												
	A	B	C	D	E	H1	H2	DNA	DNM	I	L	M	
CB 100	122	72	328	180	140	98	228	1"G	1"G	350	195	265	15.3
CB 160	115	82	385	210	170	110	265	1"1/4 G	1"G	405	225	295	24.7